

Le DUO SALAD & JUICE

FRANCE :

18 060 F : Chrome Mat / Anthracite
18 061 F : Noir / Chrome
18 064 F : Blanc / Chrome Mat
18 066 F : Noir / Chrome Mat

BELGIQUE :

18 060 B : Satin Steel / Charcoal
18 061 B : Black / Chromed
18 066 B : Black / Satin Steel

UK :

18 060 UK : Satin Steel / Charcoal
18 061 UK : Black / Satin Steel

SUISSE :

18 060 CH : Satin Steel / Charcoal
18 061 CH : Black / Satin Steel

ALLEMAGNE :

18 060 DE : Satin Steel / Charcoal

ISRAEL :

18 060 IL : Satin Steel / Charcoal

ITALIE :

18 060 IT : Satin Steel / Charcoal
18 061 IT : Black / Satin Steel
18 063 IT : Satin Steel / Red

HOLLANDE :

18 060 NL : Satin Steel / Charcoal
18 061 NL : Black / Chromed

SCANDINAVIE :

18 060 SK : Satin Steel / Charcoal
18 061 SK : Black / Satin Steel

TURQUIE :

18 060 TU : Satin Steel / Charcoal
18 061 TU : Black / Satin Steel

Le DUO SALAD & JUICE

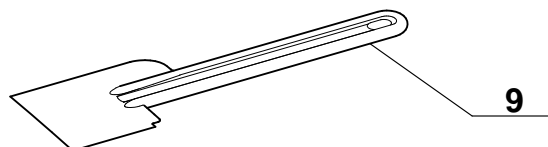
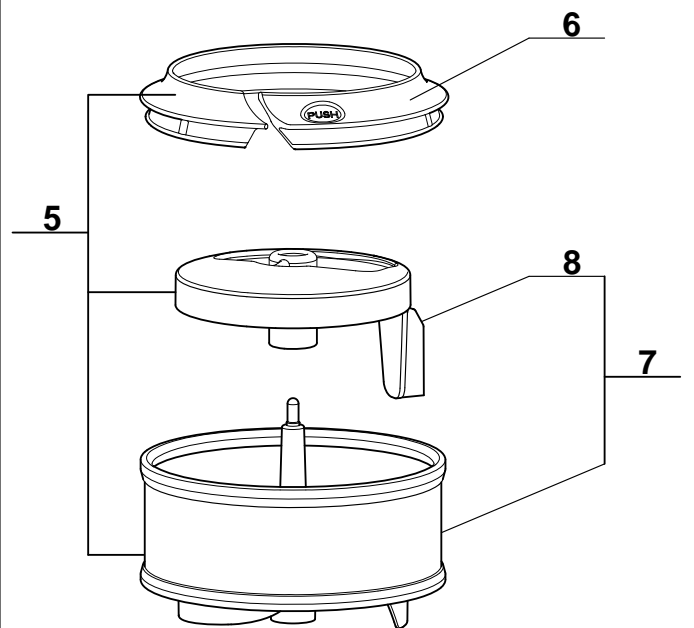
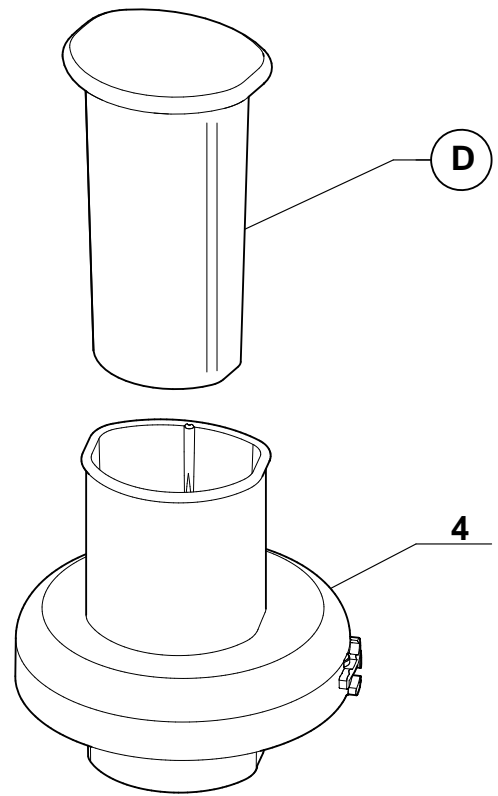
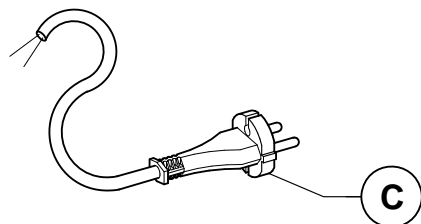
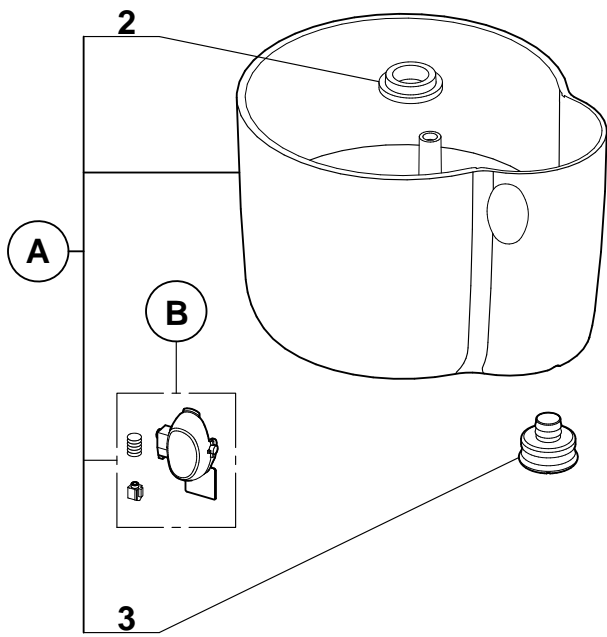
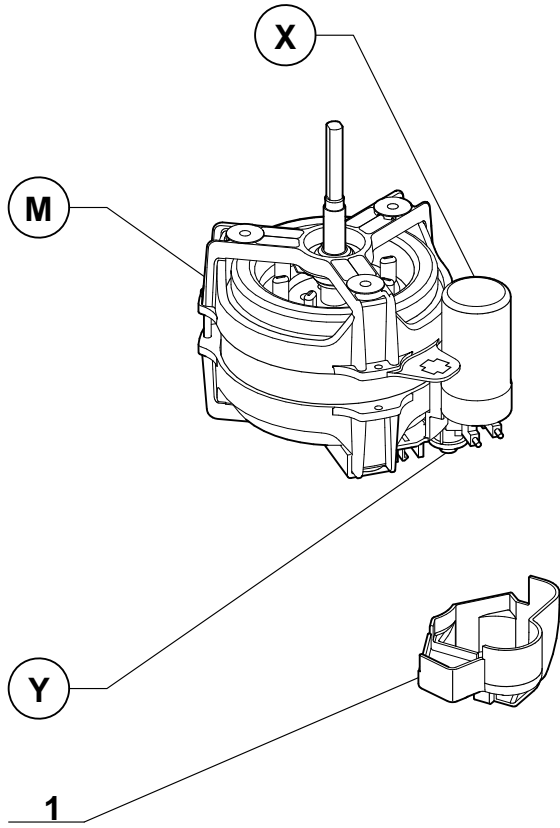

Le DUO SALAD & JUICE

Index	Pièce / Part	Désignation	Description
1	106 184	CACHE CONDENSATEUR	HIDE CPNDENSATOR
2	101 509	RONDELLE DE CALAGE	WEDGING WASHER
3	101 939	PIEDS NOIRS	BLACK FEET
4	17 432	COUVERCLE DUO XL	DUO XL LID
5	101 266	PANIER CENTRI COMPLET	COMPLETE JUICE EXTRACTOR BASKET
6	107 663	COLLERETTE DEMONTABLE	ROMOVABLE COLAR
7	100 416	PANIER DE CENTRIFUGEUSE	JUICE EXTRACTOR BASKET
8	100 700	OUTIL PRESSEUR	PRESS TOOL
9	100 098	SPATULE	SPATULE

Index	Désignation	Description
A	SOCLE	BASE
B	TOUCHE MARCHE / ARRET	ON / OFF SWITH
C	CABLE D'ALIMENTATION	POWER CORD
D	POUSSOIR DUO XL	DUO XL PUSHER
M	MOTEUR	MOTOR
X	CONDENSATEUR	CONDENSATOR
Y	RELAIS	RELAY

Machine	Voltage	A	B	C	D	M	X	Y
FRANCE								
18 060 F	230-50	107 203	106 293	504 583	106 163	3 159	603 614	500 256
18 061 F	230-50	107 659	107 661	504 583	107 645	3 159	603 614	500 256
18 064 F	230-50	107 659	107 661	504 583	107 645	3 159	603 614	500 256
18 066 F	230-50	107 659	107 661	504 583	107 645	3 159	603 614	500 256
BELGIQUE								
18 060 B	230-50	107 203	106 293	504 583	106 163	3 159	603 614	500 256
18 061 B	230-50	107 659	107 661	504 583	107 645	3 159	603 614	500 256
18 066 B	230-50	107 659	107 661	504 583	107 645	3 159	603 614	500 256
UK								
18 060 UK	230-50	107 203	106 293	504 585	106 163	3 159	603 614	500 256
18 061 UK	230-50	107 659	107 661	504 583	107 645	3 159	603 614	500 256
SUISSE								
18 060 CH	230-50	107 203	106 293	504 645	106 163	3 159	603 614	500 256
18 061 CH	230-50	107 659	107 661	504 645	107 645	3 159	603 614	500 256
ALLEMAGNE								
18 060 DE	230-50	107 203	106 293	504 583	106 163	3 159	603 614	500 256
ISRAEL								
18 060 IL	230-50	107 203	106 293	504 647	106 163	3 159	603 614	500 256
ITALIE								
18 060 IT	230-50	107 203	106 293	504 583	106 163	3 159	603 614	500 256
18 061 IT	230-50	107 659	107 661	504 583	107 645	3 159	603 614	500 256
18 063 IT	230-50	107 659	107 661	504 583	107 645	3 159	603 614	500 256

Le DUO SALAD & JUICE

Machine	Voltage	A	B	C	D	M	X	Y
HOLLANDE								
18 060 NL	230-50	107 203	106 293	504 583	106 163	3 159	603 614	500 256
18 061 NL	230-50	107 659	107 661	504 583	107 645	3 159	603 614	500 256
SCANDINAVIE								
18 060 SK	230-50	107 203	106 293	504 583	106 163	3 159	603 614	500 256
18 061 SK	230-50	107 659	107 661	504 583	107 645	3 159	603 614	500 256
TURQUIE								
18 060 TU	230-50	107 203	106 293	504 583	106 163	3 159	603 614	500 256
18 061 TU	230-50	107 659	107 661	504 583	107 645	3 159	603 614	500 256

Le DUO SALAD & JUICE

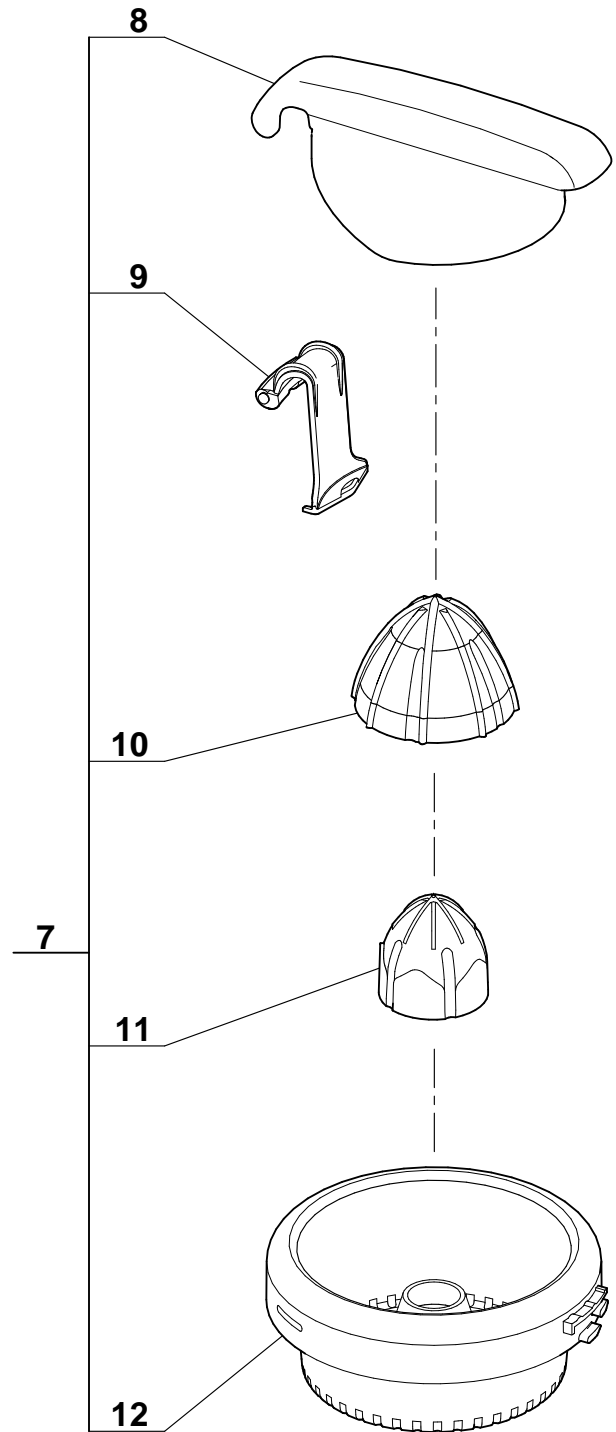
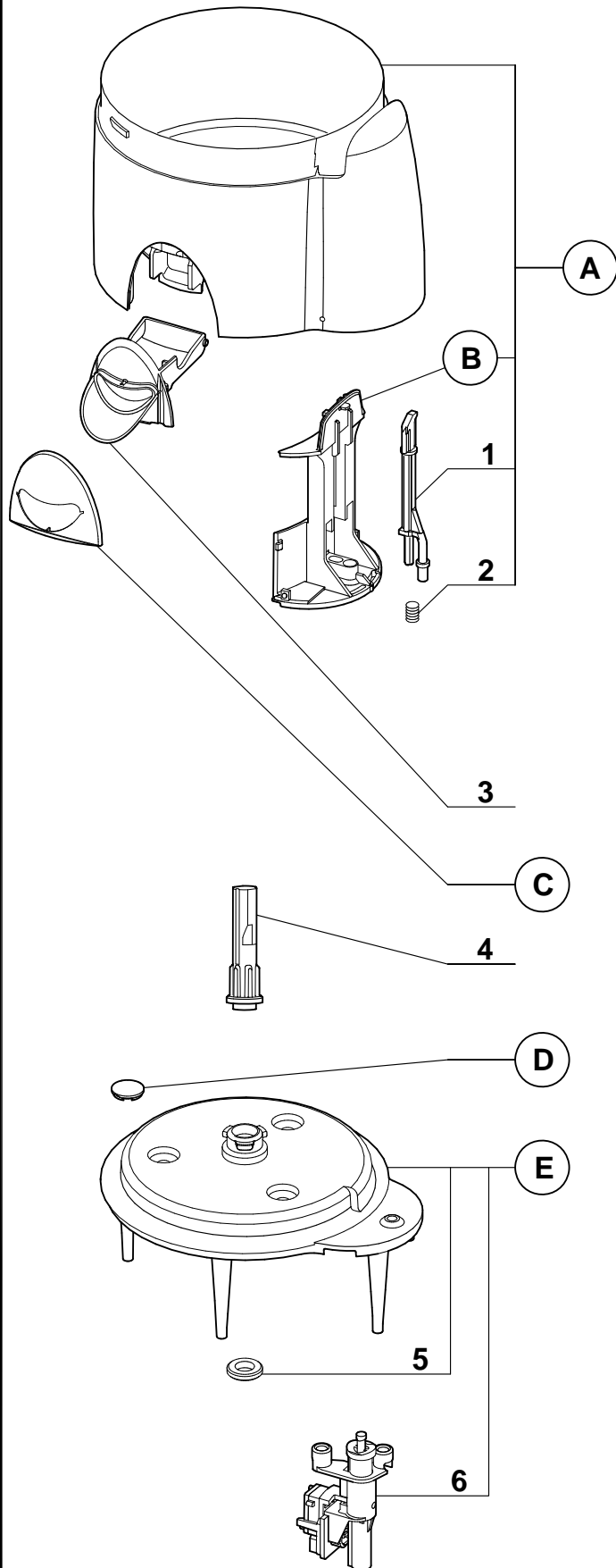

Le DUO SALAD & JUICE

Index	Pièce / Part	Désignation	Description
1	107 468	TIGE DE SECURITE	SAFETY PIN
2	106 634	RESSORT	SPRING
3	104 458	BEC VERSEUR	METAL SPOUT
4	100 408	FOURREAU	MOTORSHAFT SLEEVE
5	503 646	BAGUE ETANCHEITE	MOTORSHAFT SEAL RING
6	106 182	MINIRUPTEUR	MICROSWITCH
7	100 597	PRESSE AGRUME	CITRUS PRESS
8	100 259	BRAS	ANTI-SPLASH
9	100 277	ATTACHE BRAS	ANTI-SPLASH CLIP
10	100 258	GRAND CONE	LARGE CONE
11	100 663	PETIT CONE	SMALL CONE
12	100 273	PANIER ANTHRACITE	ANTHRACITE BASKET

Index	Désignation	Description
A	ENSEMBLE CUVE	BOWL ASSEMBLY
B	BOUCHON DE TIGE	SAFETY PIN LID
C	HABILLAGE BEC	METAL SPOUT EQUIPEMENT
D	CACHE VIS	SCREW PROTECTOR
E	SUPPORT MOTEUR	MOTOR SUPPORT

Machine	Voltage	A	B	C	D	E
FRANCE						
18 060 F	230-50	17 288	104 600	104 677	102 696	106 180
18 061 F	230-50	17 492	104 604	104 676	117 529	106 862
18 064 F	230-50	17 161	104 457	104 676	101 508	106 457
18 066 F	230-50	17 492	104 604	104 676	117 529	106 862
BELGIQUE						
18 060 B	230-50	17 288	104 600	107 677	102 696	106 180
18 061 B	230-50	17 492	104 604	104 676	117 529	106 862
18 066 B	230-50	17 492	104 604	104 676	117 529	106 862
UK						
18 060 UK	230-50	17 288	104 600	104 677	102 696	106 180
18 061 UK	230-50	17 492	104 604	104 676	117 529	106 862
SUISSE						
18 060 CH	230-50	17 288	104 600	104 677	102 696	106 180
18 061 CH	230-50	17 492	104 604	104 676	117 529	106 862
ALLEMAGNE						
18 060 DE	230-50	17 288	104 600	104 677	102 696	106 180
ISRAEL						
18 060 IL	230-50	17 288	104 600	104 677	102 696	106 180
ITALIE						
18 060 IT	230-50	17 288	104 600	104 677	102 696	106 180
18 061 IT	230-50	17 492	104 604	104 676	117 529	106 862
18 063 IT	230-50	17 519	105 843	104 676	117 825	106 493

Le DUO SALAD & JUICE

Machine	Voltage	A	B	C	D	E
HOLLANDE						
18 060 NL	230-50	17 288	104 600	104 677	102 696	106 180
18 061 NL	230-50	17 492	104 604	104 676	117 529	106 862
SCANDINAVIE						
18 060 SK	230-50	17 288	104 600	104 677	102 696	106 180
18 061 SK	230-50	17 492	104 604	104 676	117 529	106 862
TURQUIE						
18 060 TU	230-50	17 288	104 600	104 677	102 696	106 180
18 061 TU	230-50	17 492	104 604	104 676	117 529	106 862

Le DUO SALAD & JUICE

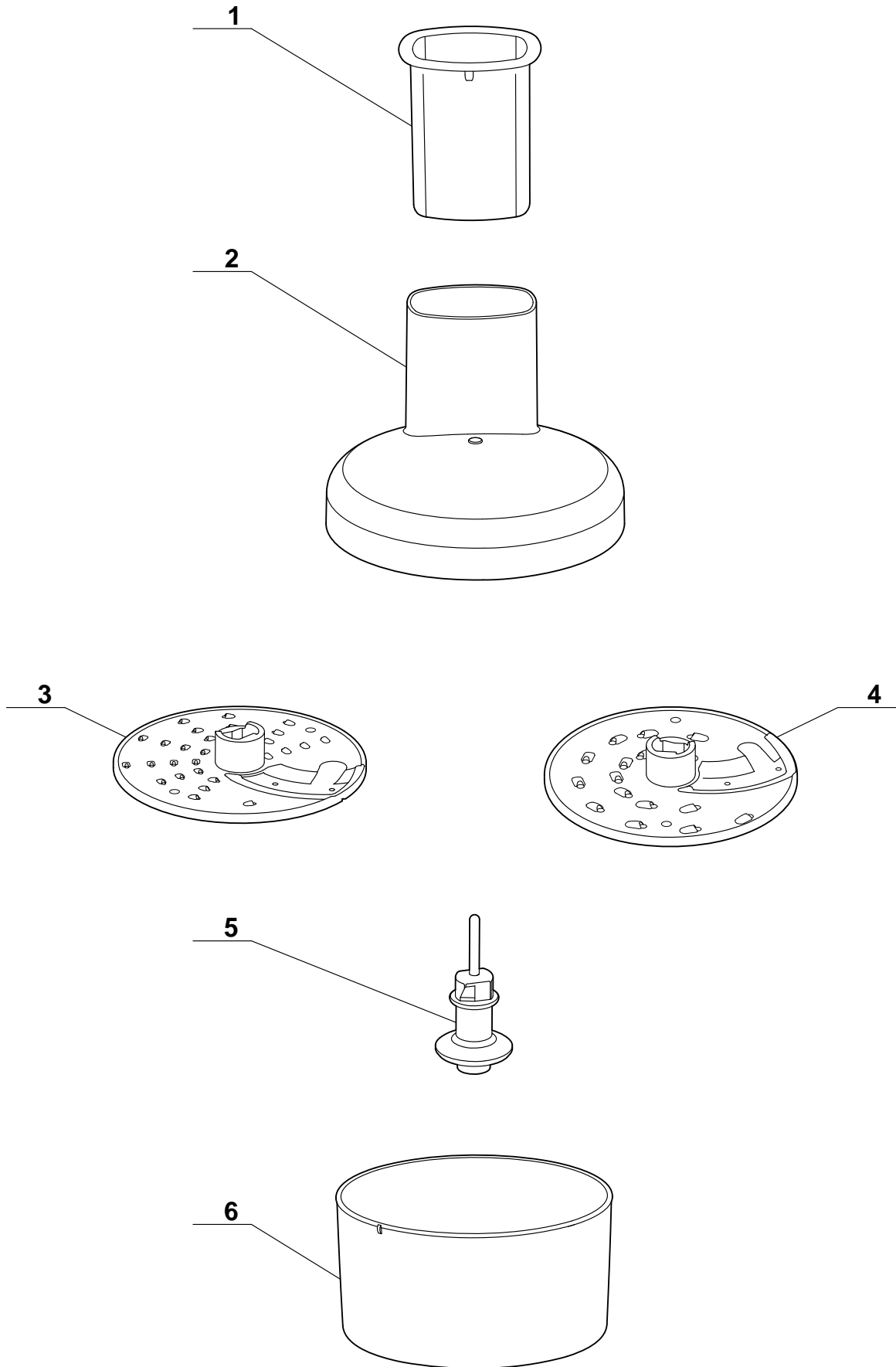

Le DUO SALAD & JUICE

<i>Index</i>	<i>Pièce / Part</i>	<i>Désignation</i>	<i>Description</i>
1	17 221	POUSSOIR	PUSHER
2	17 469	COUVERCLE	LID
3	17 363	EMINCEUR – RAPEUR 2 mm	SLINCING – GRATING DISC 2 mm
4	17 364	EMINCEUR – RAPEUR 4 mm	SLINCING – GRATING DISC 4 mm
5	103 946	PROLONGATEUR DE DISQUE	DETACHABLE DISC SUPPORT
6	17 038	MIDI CUVE DUO SALAD	LINER BOWL DUO SALAD